

The Evolution of Flight Data Analysis

Neil A. H. Campbell MO3806

Neil graduated in 1983, with a Bachelor of Engineering degree (Electronics), from the University of Western Australia. In 1986 he joined the Bureau of Air Safety Investigation as a flight recorder specialist. Neil took a leave of absence during 1994-1995 and managed the flight data analysis program for Gulf Air in Bahrain. During 1998 he was a member of the ICAO Flight Recorder Panel that developed changes to ICAO Annex 6. In February 2000, Neil joined the Corporate Safety Department of Cathay Pacific Airways Limited in Hong Kong. During 2001 and 2002 he held the position of Manager Air Safety. In December 2003 he rejoined the Australian Transport Safety Bureau as a Senior Transport Safety Investigator.

CONTENTS

- 1. Introduction**
- 2. History of flight recording**
- 3. Data collection**
 - 3.1 Flight data recorders**
 - **Boeing 707**
 - **Airbus A330**
 - **Embraer 170**
 - **Airbus A380**
 - **Boeing 787**
 - 3.2 Onboard avionics**
 - 3.3 ATC datalink message recording**
 - 3.4 ADS-B data**
- 4. Data recovery**
 - 4.1 Wireless transmission of QAR data**
 - 4.2 FDR data recovery**
 - 4.3 FDR system documentation**
- 5. Readout equipment**
- 6. Analysis**
 - 6.1 Data listings and plots**
 - 6.2 Airline flight data analysis programs**
 - 6.3 Animations**
 - 6.4 Simulations**
 - 6.5 Comparison techniques**
 - 6.6 Geographical Information System (GIS) Tools**
- 7. Conclusion**

1. INTRODUCTION

Although the usefulness of flight data recorders (FDR's) and cockpit voice recorders (CVR's) for accident investigation purposes is now well accepted, this has not always been the case. Consider this report from 1962¹ referring to the introduction of CVR's to the UK "...there is pretty general agreement in the UK that speech is of little, if any, real use, and furthermore that anything above 15 minutes recording is a waste. The requirement, if it comes, is expected to be 5 minutes."

This paper describes the evolution of flight data analysis for commercial aircraft and considers the entire process from data collection, data recovery, readout equipment and analysis tools.

2. HISTORY OF FLIGHT RECORDING

"During World War II the NACA² V-g recorder³ was introduced in transport, bomber and fighter aircraft to assess the operational loads met infrequently and structural design requirements for aircraft. This instrument records the peak accelerations and the speed at which these occur in flight. By 1950 the data from these instruments had become inadequate due to the importance of fatigue damage and the need for aircraft height to assess the structural and aerodynamic implications of gust or manoeuvre loads. Thus V-g-h continuous trace recorders in the USA and counting accelerometers in the UK were introduced in the early 1950's.⁴"

In Australia, Dr David Warren was certain of the importance of recorded data for accident investigation purposes and he and his team at ARL⁵ pioneered the development of a combined voice and data recorder.⁶

During the 1960's, regulatory authorities around the world began to require FDR's and CVR's to be fitted to large commercial aircraft. Today the FDR and CVR are an accepted part of aviation with the debate now about the need for image recorders and extending recorder carriage requirements to smaller aircraft.

Figure 1: Developments in solid-state FDR's show a decrease in size and weight⁷



¹ Aircraft – Australasia's Aviation Magazine, July 1962, page 28.

² NACA: National Advisory Committee for Aeronautics.

³ V-g recorder: a non-crash protected device that recorded indicated airspeed (V) and load factor (g).

⁴ J.R. Sturgeon (1969), *Technical Prospects of the Use of Digital Flight Recorders for Operational Research and Accident Prevention*, RAE Technical Report 69201.

⁵ ARL: Aeronautical Research Laboratory.

⁶ <http://www.dsto.defence.gov.au/page/3383/>

⁷ Photograph from M. H. Thompson, *A Vision of Future Crash Survivable Recording Systems*, Honeywell.

3. DATA COLLECTION

3.1 Flight data recorders

Both crash-protected flight data recorders (FDR's) and optional quick access recorders (QAR's) began to be installed on commercial aircraft in the 1960's. The evolution of these data collection devices is shown by using the following aircraft types as examples:

Aircraft Type	Introduced into service	FDR Type	Number of parameters	FDR data capacity
Boeing 707	1958	Analogue	5	Mechanical limit of about 10 parameters
Airbus 330	1993	Digital (solid-state or tape medium)	280	128 wps ⁸ (serial data input)
Embraer 170	2004	Digital (solid-state) combi-recorder	774	256 wps (serial data input)
Airbus 380	2007	Digital (solid-state)	> 1,000	1,024 wps (serial data input)
Boeing 787	2009	Digital (solid-state) EAFR ⁹	> 1,000	Ethernet system

⁸ wps: words per second. An FDR word consists of 12 bits.

⁹ EAFR: Enhanced Airborne Flight Recorder. A combi-recorder that stores both cockpit audio and flight data. The EAFR also has the capability of storing video information.

Boeing 707

The Boeing 707 (B707) was typically equipped with a five parameter¹⁰ analogue FDR. Data was recorded by engraving traces onto a metal foil. Within the recorder were pitot/static and electrical sensors separate to the aircraft sensors used by the crew. Calibration of the FDR sensors and general reliability of a mechanical recorder were problems for investigators relying on this data.

Figure 2: Access to FDR via access panel in rear fuselage



Figure 3: The canister in the tail containing the FDR



¹⁰ Pressure altitude, indicated airspeed, magnetic heading, vertical acceleration (load factor) and microphone (radio) keying versus time.

Figure 4: The FDR inside the canister

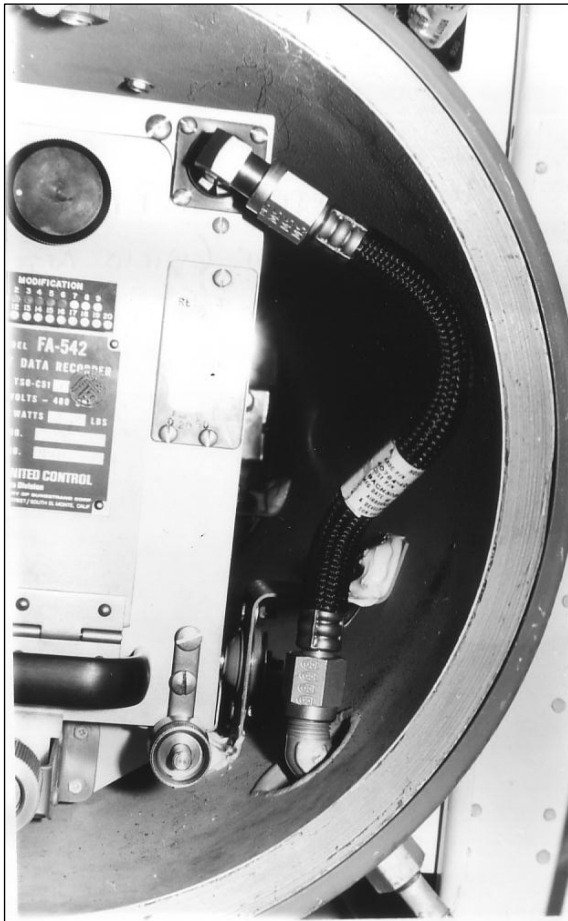

Figure 5: Lockheed Aircraft Service model LAS-109C FDR



The canister improved the reliability of the FDR by protecting it from the pressure, temperature and humidity variations experienced inside the unpressurised tail of the B707. An alternative FDR for the B707 was the Lockheed Aircraft Service model LAS-109C FDR. It was a spherical analogue recorder and was coloured yellow - it weighed 15.4 kg. The pneumatic and electrical connections to the FDR are visible in Figure 5.

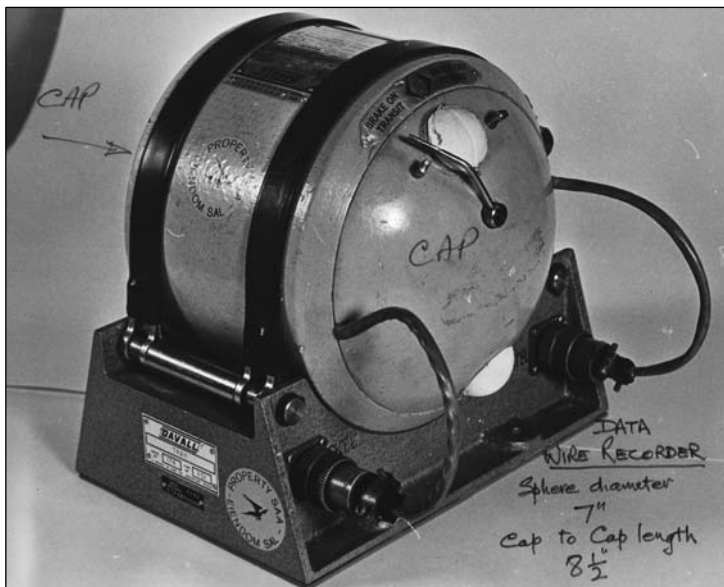

Figure 6: Davall Wire FDR

Some later model B707's were equipped with an early type of digital FDR. This recorder was coloured flame orange and was known as a "red egg". A digital multiplexing technique was used and the data was magnetically recorded onto a thin wire. This technique was based on the black box prototype developed by the Australian scientist Dr David Warren.

Airbus A330

The A330 is equipped with a solid-state FDR and a separate solid-state CVR. The FDR receives data from an interface unit¹¹ so the FDR system is a two-box system. Additionally some airlines choose to fit a QAR¹² that receives data from the same interface unit as the FDR and records the same parameters as the FDR. Figure 7¹³ shows a QAR and FDR connected to the same acquisition unit. This configuration requires three boxes.

A QAR can also receive data from a separate Data Management Unit (DMU). When a DMU is used, Airbus label the recorder a DAR¹⁴ rather than a QAR. With a DMU, the airline can program the parameters that the DAR will record so it is more flexible than a QAR which records exactly the same parameters as the FDR. Four separate avionics boxes are required for an aircraft equipped with an FDR and a DAR.

Figure 7:

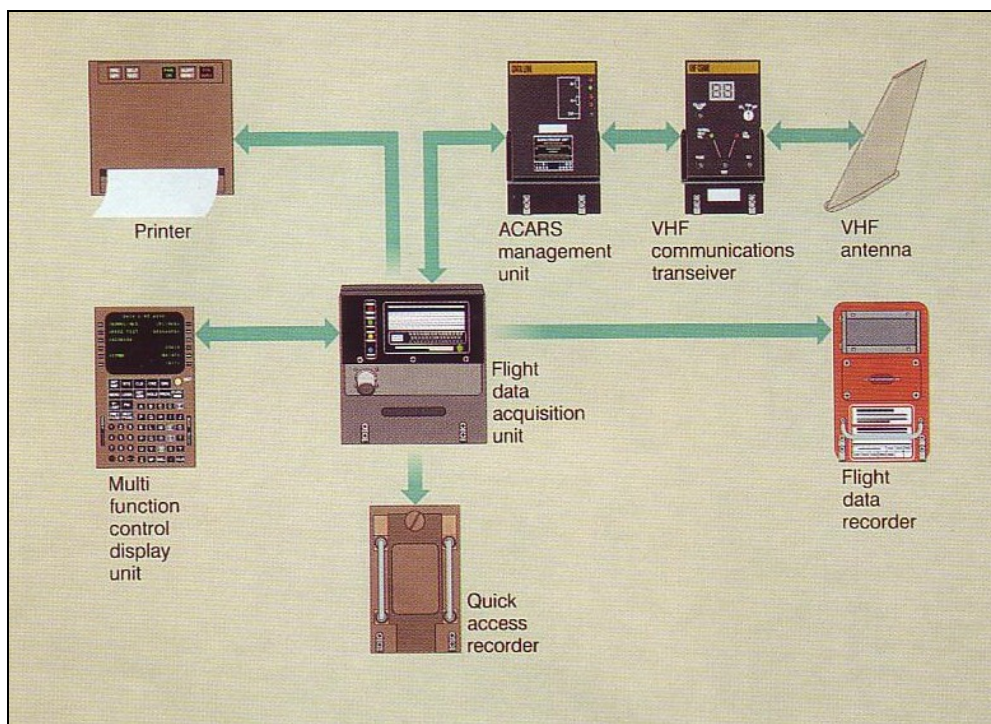

¹¹ Flight Data Interface Unit (FDIU) in Airbus terminology or Flight Data Acquisition Unit (FDAU) in Boeing terminology.

¹² QAR: Quick Access Recorder. An optional non-crash protected recorder that airlines can install to provide access to flight data. It is more accessible and can record for a longer duration than the FDR.

¹³ *Flight Data Recording & Airplane Condition Monitoring*, Boeing Airliner magazine, April-June 1992, page 4.

¹⁴ DAR: Digital ACMS Recorder.

Embraer 170

Embraer 170 aircraft are equipped with two digital voice data recorders (DVDR's). A DVDR is a combi-recorder that records both cockpit audio and flight data in a single box. To improve the probability of both audio and flight data surviving an accident, one DVDR is located in the front of the aircraft and one in the rear of the aircraft as shown in Figure 8. There is an advantage to the operator in having only a single part number in their inventory and presumably some MEL relief would apply as well.

Figure 8: DVDR location in the Embraer 170¹⁵

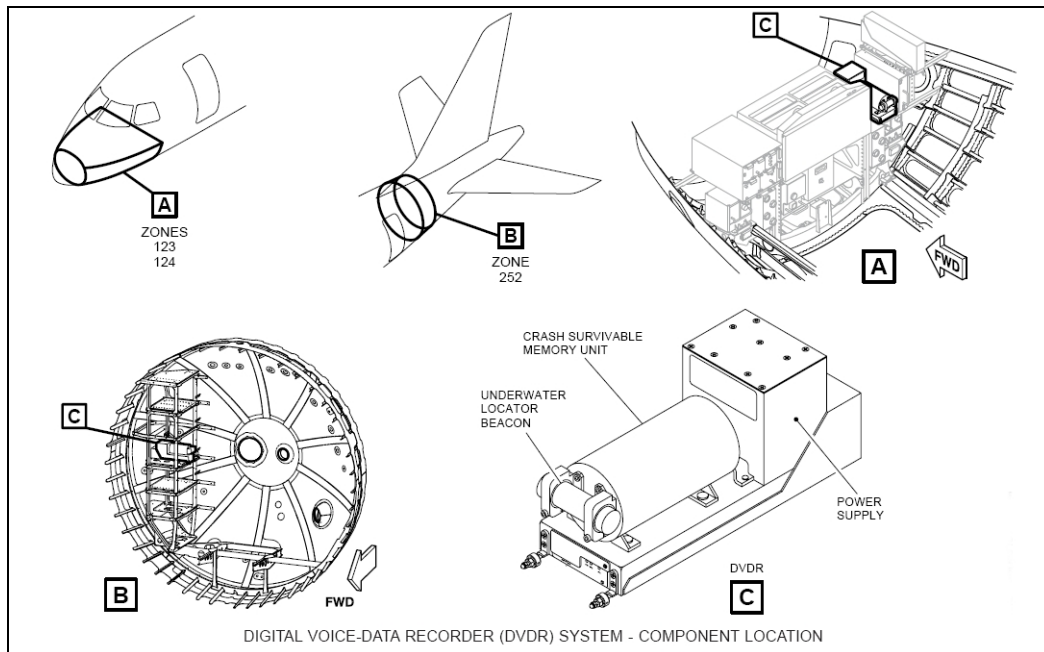

Airbus A380

The A380 will have a networked avionics architecture but will retain the standard configuration of a solid-state FDR and a separate solid-state CVR. Rather than a separate QAR, A380 operators will be able to use the two servers that will be installed onboard running the Linux operating system. Information stored on the servers will include flight data, flight operations quality assurance data, electronic flight bag documents and other software. The two Airbus servers will receive data through a secure communications interface from the A380's Avionics Full Duplex (AFDX) switched ethernet avionics network¹⁶.

A380 operators will be able to choose to add a third server attached to the network through a secure router. The operator can then host its own applications and modify them at will as long as configuration control is maintained. Applications such as weight and balance, troubleshooting guides and wiring diagrams could be hosted.

¹⁵ From the Embraer 170/175 Aircraft Maintenance Manual.

¹⁶ Aviation Today, *Virtual Data Acquisition*, January 2004.

Boeing 787

Figure 9: Boeing 787 ‘Dreamliner’



The B787 will have a networked avionics architecture and will be fitted with two enhanced airborne flight recorders (EAFR's). Each EAFR will combine the functions of a CVR and FDR giving system redundancy. A separate flight data acquisition unit (FDAU) will not be needed as a 'virtual FDAU' will be distributed among other software and hardware including the EAFR itself. This will reduce the total weight as a separate line replaceable unit for the FDAU will not be needed.

3.2 Onboard avionics

Modern commercial airliners contain many avionics systems that record data in non-volatile memory. Although not crash-protected, these sources of data can be very useful for accident or incident investigations, particularly when FDR or QAR data is not available. The EGPWS¹⁷ computer is an example of a source of valuable data stored by onboard avionics equipment¹⁸.

3.3 ATC datalink message recording

Datalink messages such as CPDLC¹⁹ transmissions are required to be recorded. Originally the ICAO requirement was only going to require recording of messages that affected the trajectory of the aircraft but in practice it would have been difficult to separate these messages from other messages. It is simpler to record all messages, however, this is not as straightforward as it appears as enough information needs to be recorded so that investigators can know:

- the contents of a received message
- its priority
- the number of messages in the uplink/downlink queues
- the contents of a message generated by the crew
- the time each downlink message was generated
- the time any message was available for display to the crew
- the time any message was actually displayed to the crew.

While these datalink messages could be recorded on the FDR or CVR, in practice they will be recorded on the CVR and retained for the duration of the CVR (typically 2 hours).

¹⁷ EGPWS: Enhanced Ground Proximity Warning System.

¹⁸ Refer to this case study for more information on EGPWS data:

<http://www.asasi.org/papers/2005/Use%20of%20EGPWS.pdf>

¹⁹ CPDLC: Controller-Pilot Data Link Communications.

Figure 10: Extract from ICAO Annex 6

6.3.1.5 All aeroplanes for which the individual certificate of airworthiness is first issued after 1 January 2005, which utilize data link communications and are required to carry a CVR, shall record on a flight recorder, all data link communications to and from the aeroplane. The minimum recording duration shall be equal to the duration of the CVR, and shall be correlated to the recorded cockpit audio.

6.3.1.5.1 From 1 January 2007, all aeroplanes which utilize data link communications and are required to carry a CVR shall record on a flight recorder, all data link communications to and from the aeroplane. The minimum recording duration shall be equal to the duration of the CVR, and shall be correlated to the recorded cockpit audio.

6.3.1.5.2 Sufficient information to derive the content of the data link communications message and, whenever practical, the time the message was displayed to or generated by the crew shall be recorded.

Note.— Data link communications include, but are not limited to, automatic dependent surveillance (ADS), controller-pilot data link communications (CPDLC), data link-flight information services (D-FIS) and aeronautical operational control (AOC) messages

Figure 11: Example presentation of a datalink message on a cockpit MCDU²⁰



3.4 ADS-B data

Mode S²¹ transponders are carried by large airliners. There are two types of Mode S – elementary surveillance and enhanced surveillance. Enhanced Mode S has a datalink capability that can be used in providing an air traffic management function. ADS-B²² is such a function and uses Mode S as the datalink technology.

ADS-B data transmitted from a suitably equipped aircraft includes:

- time/date stamp
- flight number
- Mode S ID (unique 24 bit address for a particular aircraft)
- latitude and longitude
- actual pressure altitude
- selected altitude or flight level
- groundspeed
- track angle
- vertical rate

The update rate is approximately once per second. Mode S receivers that can decode ADS-B data are commercially available. An example is the SBS-1 base station manufactured by Kinetic Avionic Products Ltd of the UK. Figure 12 shows the receiver unit and aerial and Figure 13 shows the pseudo-radar display produced by the base station software.

²⁰ MCDU: Multi-function Control and Display Unit.

²¹ Mode S is a secondary surveillance radar (SSR) technique that allows selective interrogation of an aircraft using its unique 24 bit address. This removes the risk of confusion due to overlapping signals.

²² ADS-B: Automatic Dependent Surveillance – Broadcast.

Figure 12: SBS-1 Receiver and antenna



Figure 13: Display of ADS-B tracks near Canberra

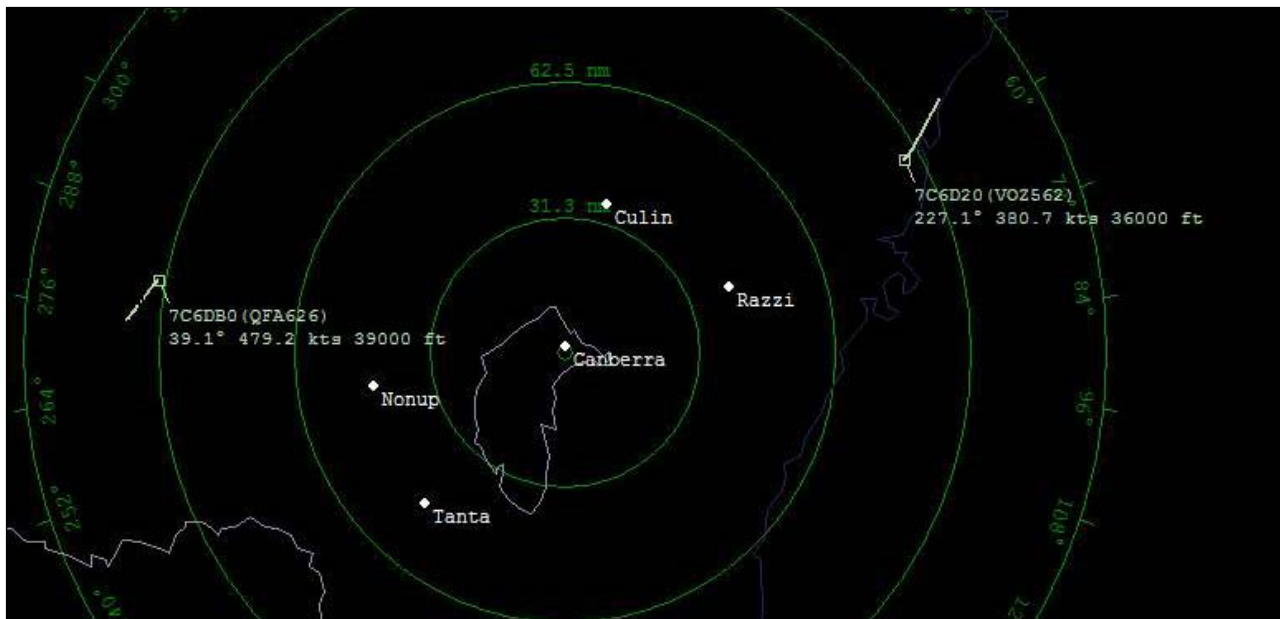

4. DATA RECOVERY

4.1 Wireless transmission of QAR data

The recording media for QAR's has evolved as follows:

- magnetic tape cartridges
- magneto-optical disks
- solid-state (eg. PCMCIA²³ cards or CF²⁴ memory).

Traditionally the recording cartridge/disk needed to be removed from each aircraft on a regular basis before the recording capacity was reached and data was lost. The cartridge/disk was then transferred to the readout facility (typically the flight safety department) where each cartridge/disk was individually handled and replayed. After replay, the cartridges/disks were stored for a sufficiently long period to allow for any necessary follow-up analysis, then reformatted and sent to stores for eventual return to an aircraft. There was an obvious cost in

²³ PCMCIA: Portable Computer Memory Card International Association.

²⁴ CF: Compact Flash.

acquiring sufficient cartridges/disks for this cycle and the manpower involved in retrieval and replay. There was also the opportunity for cartridges/disks to be lost with the loss of valuable data. The media handling statistics for one airline were:

- international aircraft: 168 (15,270 legs/month)
 - average of 124 tapes or disks per day
- domestic aircraft: 70 (11,266 legs/month)
 - average 43 disks per day

Wireless technology is now being used to transmit QAR data without the need for manual handling. This will lower the cost of data recovery and increase the timeliness and availability of data.

Figure 14: Description of Teledyne Wireless QAR²⁵

WIRELESS GROUND-LINK®



The Teledyne Controls Wireless GroundLink® (WQAR) solution enables aircraft operators to fully automate the recording and transmission of their flight data, therefore eliminating all risk of data loss involved with traditional manual procedures.

Offering unprecedented reliability, the WQAR system records and wirelessly transfers flight data from the aircraft to the ground, without any media handling and human intervention. The raw data recorded during the flight is compressed, encrypted and then securely transmitted via cellular technology and the Internet to the airline's or Teledyne's ground-based data center for processing and analysis.

Using the Teledyne Wireless GroundLink® system, the airlines can reduce data delivery delays (the data is available within 10-15 minutes after an aircraft has landed, versus several days or weeks with manual data retrieval), cut human and equipment costs associated with manual data retrieval, and eliminate data loss that can reach 30% with conventional manual methods.

<ul style="list-style-type: none"> ■ Part Number: 2243800-XX ■ Form Factor: 4MCU ■ Connector: ARINC 600 or ARINC 404 ■ Weight: 8-15 lbs / 3.6-6.8kg ■ Input Power: 115VAC 360-800HZ ■ Media Size: Up to 2GB ■ Recording Rates: From 64 to 1024 wps ■ Data Transfer Protocol: Proprietary Teledyne protocol using UDP and TCP/IP 	<div style="background-color: #003366; color: white; padding: 5px; margin-bottom: 5px;">BENEFITS AND KEY FEATURES</div> <ul style="list-style-type: none"> ■ A <i>reliable and cost effective</i> way to move data on and off the aircraft ■ QAR data retrieval from aircraft without human involvement ■ Data accumulated during the flight is compressed and encrypted for security ■ Simultaneous use of up to eight full duplex radios ■ Multi-band radios for world wide operation ■ Upgradable to support emerging cellular data standards ■ Multiple radio transmission reduces data transfer time ■ Data delivered world wide, over the Internet ■ No investment in the infrastructure—Uses existing infrastructure maintained by service providers ■ Operates in controlled cellular frequency spectrum world wide, protected from interference. ■ End-to-end automation of aircraft data retrieval and analysis when used in conjunction with Teledyne's flight data analysis tool AirFASE® * <p style="font-size: small; text-align: right; margin-top: 5px;">*Please consult our AirFASE® data sheet for further information.</p>
---	---

²⁵ <http://www.teledyne-controls.com/pdf/GroundLink.pdf>

4.2 FDR data recovery

While in-flight telemetry has been used for decades for missile launches and space travel it is unlikely to replace a fixed onboard FDR (or CVR). The reasons are:

- Cost - all in-flight data transmissions have to be paid for by the operator. While it is cost-effective to transmit snapshots of important data e.g. ACARS²⁶ it would be expensive to continuously transmit large amounts of data in-flight.
- Reliability - a satellite link would be needed to transmit data during oceanic cruise. Would this be reliable if the aircraft was experiencing electrical problems or had experienced a loss of control?
- Sovereignty issues - transmitted data may be held in a third state and not the state of occurrence or the state of the operator as defined in ICAO Annex 13. Would this data be under the control of the investigation team?

Storing data in an onboard recorder is still the cheapest and most reliable storage technique even allowing for the occasional deep-sea underwater recovery.

Data recovery, from an undamaged solid-state FDR, is performed by connecting a PC to the FDR and downloading the crash-survivable memory unit contents as shown in Figure 15.

Figure 15: Downloading data from a solid-state FDR



Damaged recorders require specialist recovery techniques that vary according to the FDR model and type of recording medium.

²⁶ ACARS: Aircraft Communications, Addressing and Reporting System.

4.3 FDR system documentation

Figure 16 shows the data flow through an FDR system. An essential step in data recovery is the engineering unit conversion where the raw binary data is mathematically processed to obtain the relevant engineering unit eg. the raw data recorded for indicated airspeed is converted to knots. For modern airliners, recording hundreds or thousands of parameters, it is a huge task to obtain accurate system documentation, develop the parameter conversion equations and validate the results. Figure 17 shows the documentation for a Boeing 777.

Figure 16: Data acquisition, recording, recovery and analysis

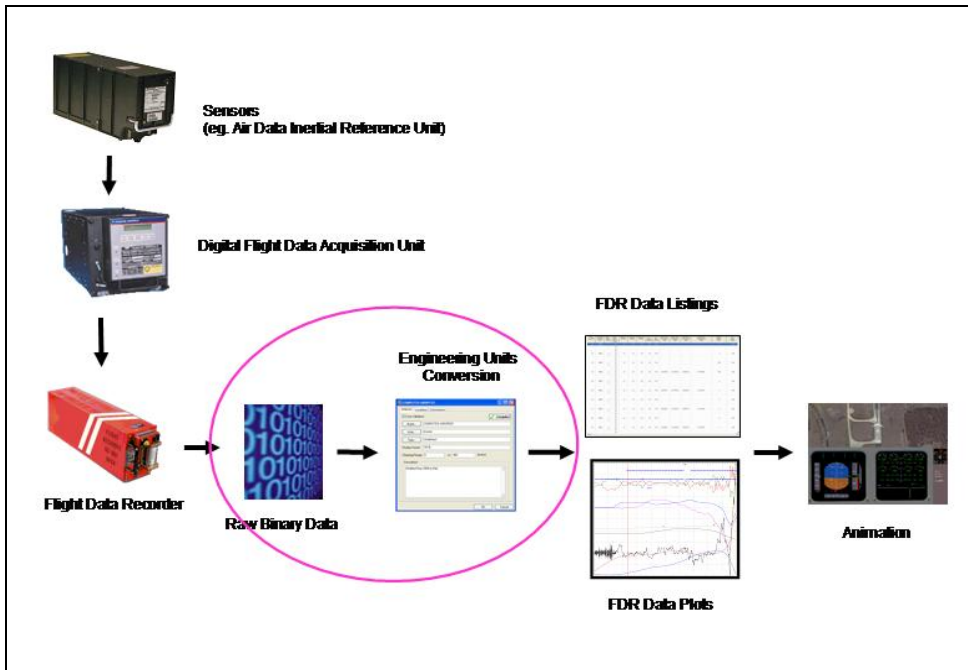
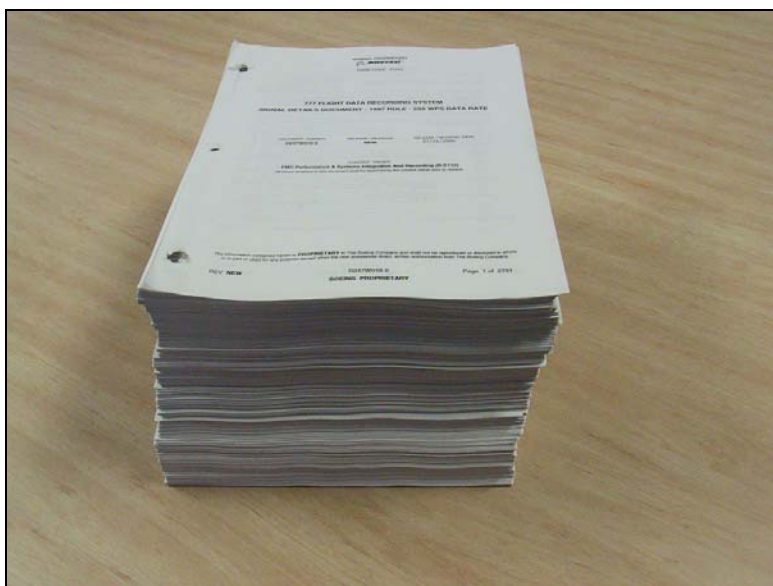

Figure 17: Boeing B777 FDR system documentation



To aid this process, a specification for Flight Recorder Electronic Documentation (FRED) is being developed with the aim of storing the documentation within the recorder memory itself. An XML format is being proposed with the documentation being able to be read by a browser. This would end the situation of investigation agencies struggling to find up-to-date system documentation in a timely way after an accident.

5. READOUT EQUIPMENT

The first generation of FDR's were analogue devices that recorded data by engraving traces on a metal foil. To readout the data, the foil was placed on a microscope table where distances could be accurately measured, correction factors applied and the parameter values derived. It was a laborious process. Figure 18 shows an example of such a microscope table.

Figure 18: Early Australian readout equipment for analogue FDR's



The first generation of digital FDR's appeared in the 1970's and an example of a readout station is shown in Figure 19. It was capable of producing data listings and plots.

Figure 19: An early UK readout station for digital FDR's²⁷



²⁷ W.H. Tench (1973), *Read-out and analysis of Flight Data Recordings*, Accidents Investigation Branch, UK.

The first flight recorder readout system for commercial aircraft in Australia was acquired in 1972 by the Air Safety Investigation Branch²⁸. It was called the FRAN (Flight Recorder ANalysis) system and consisted of a DEC PDP 11/05²⁹ mini-computer.

The FRAN system was regularly upgraded over the following decades and eventually two mini-computers were used – a PDP 11/45 and a PDP 11/73. The FRAN system was eventually phased-out in 1999.

Figure 20: BASI FRAN system

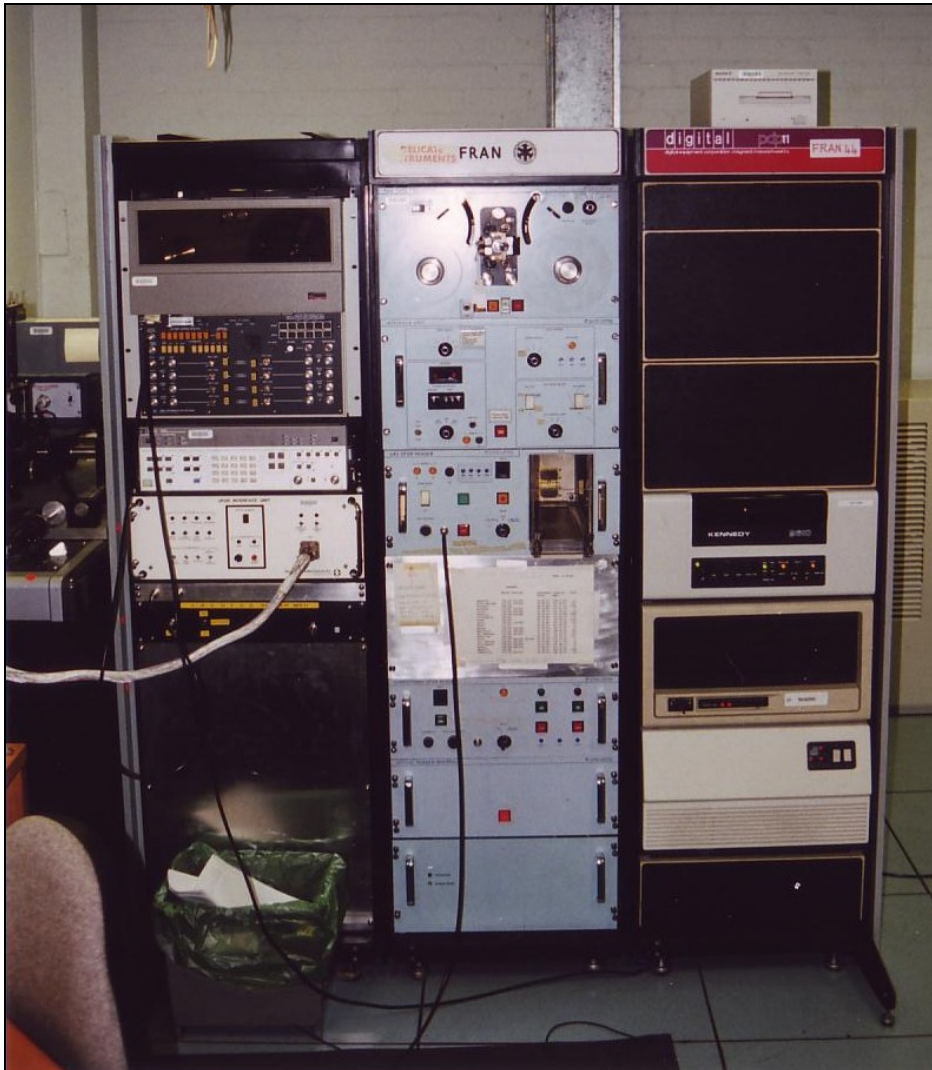

In 1991, a decision was made at BASI to standardise on the computer graphics system being developed at the Canadian Transport Safety Board - the Recovery, Analysis and Presentation system (RAPS). Development of a BASI in-house system ceased. To obtain the necessary performance, RAPS used Hewlett-Packard Unix workstations which were reliable but expensive.

²⁸ In 1982, the Air Safety Investigation Branch (ASIB) was re-organised to become the Bureau of Air Safety Investigation (BASI). On 1 July 1999, the multi-modal Australian Transport Safety Bureau was created by combining BASI with other agencies.

²⁹ DEC: Digital Equipment Corporation, PDP: Programmable Data Processor.

Figure 21: Unix workstation



In 1992, the commercial development of RAPS was taken over by Flightscape Inc. and the software, now called 'Insight', was begun to be converted for use on a PC. This allowed advantage to be taken of the rapid increase in performance and low cost of PC hardware. In 2005, the ATSB adopted the use of Insight and flight recorder specialists operate the complete system on their laptops, effectively giving them a portable flight recorder laboratory.

Figure 22: Laptop running Insight animation

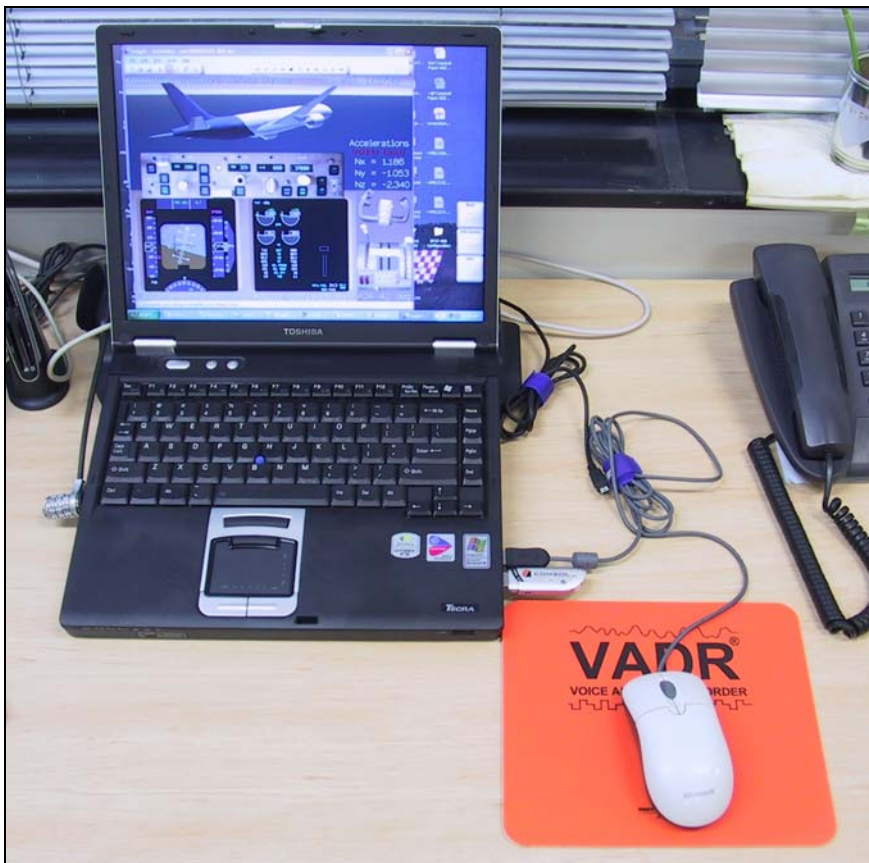

6. ANALYSIS

Figure 23: Data recording, recovery and analysis

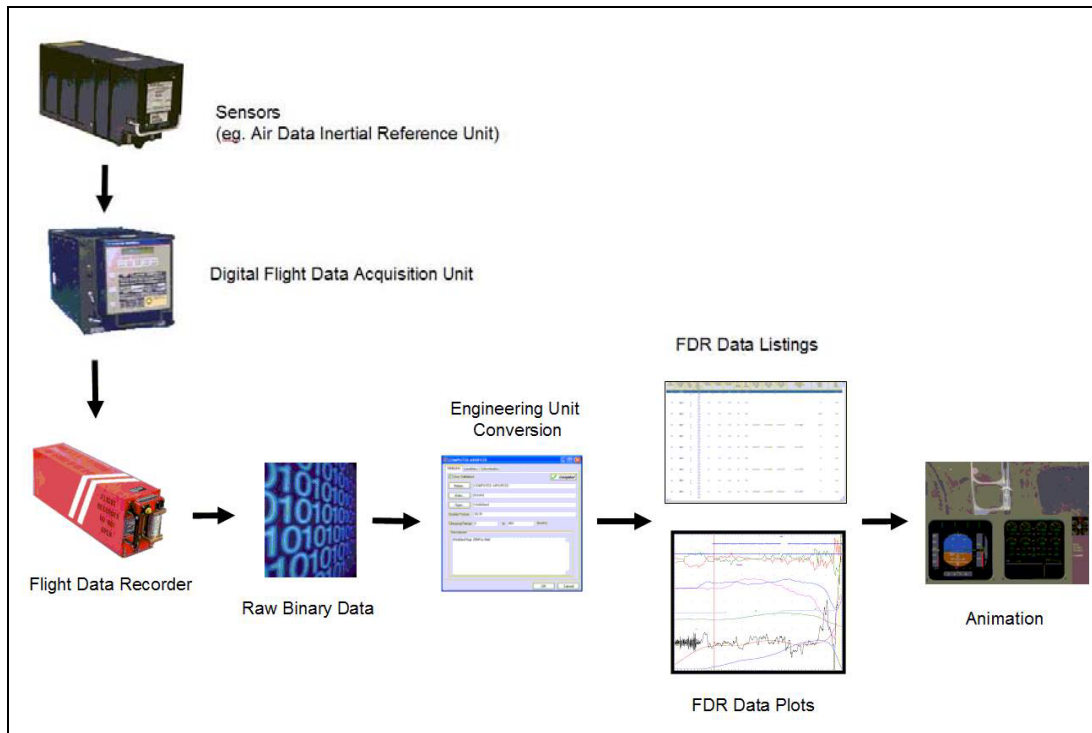

6.1 Data listings and plots

Data listings and plots have been used since the first generation of FDR's was introduced. By examining the data (particularly with a plot) mutual compatibility between parameters can be checked, for example, if the value of magnetic heading increases then the roll attitude parameter should show a bank to the right.

With only a small number of parameters being recorded by the first generation of FDR's, it was necessary to derive other important parameters. For instance, rate of climb and descent could be obtained from altitude versus time, bank angle from indicated airspeed and rate of change of heading and Mach number from pressure altitude, indicated airspeed and temperature.

Another technique used was the total energy graph³⁰. By producing a graph of total energy (potential energy and kinetic energy) versus time, it was possible to estimate when changes in aircraft configuration or engine thrust occurred.

Modern airliners use digital databuses to transfer data between aircraft systems. FDR's have access to these databuses and now thousands of parameters are easily available for recording. The historical techniques of deriving parameters are now rarely required for modern airliners but still required for older FDR installations that record only basic parameters.

³⁰ R. G. Feltham (1973), *Aircraft Accident Data Recording Systems*, UK Department of Trade and Industry, page 62.

6.2 Airline flight data analysis programs

An airline flight data analysis program (FDAP)³¹ involves the routine scanning of flight data (obtained from FDR's or QAR's) to detect flight operations events. They are typically set up with the cooperation of the relevant pilot association and are cooperative programs. Flight operations events can be chosen to coincide with the airline's standard operating procedures. Examples of flight operations events are:

- limit speeds (flap, gear, V_{MO} , M_{MO})
- GPWS/TCAS activations
- pitch/roll limits
- rushed approaches (rates of descent, late landing flaps etc).

Since 1st January 2005, ICAO Annex 6 has required operators of large airliners to establish and maintain a FDAP. FDAP is a risk management process and aims to:

- identify and quantify existing operational risks
- identify and quantify changing operational risks
- formally assess the risk to determine which are not acceptable
- where risks are not acceptable, put in place remedial activity
- measure the effectiveness of action and continue to monitor risks.

Despite the ICAO requirement only applying from 2005, many airlines have been operating successful FDAP programs for decades, for example, British Airways pioneered a FDAP in the 1960's. The UK government also pioneered flight data analysis for civilian aircraft through its Civil Aircraft Airworthiness data Recording Program (CAADRP)³². The aims of CAADRP were to study:

- *the effect of environment and operational usage on the aeroplane*
- *the way the aeroplane is operated within the bounds of its inherent capabilities*
- *unusual occurrences caused by environment, operational usage or malfunction of some part of the aeroplane.*

6.3 Animations

Animations are useful as they:

- help to assimilate large amounts of data
- place sequence of events into time perspective
- link recorded data with ground features
- correlate FDR data with other sources of data e.g. CVR audio, radar data or eyewitnesses
- useful analysis tool for operations investigators
- aids explanation of incident to lay persons
- training/educational tool.

Animations can show a 3-dimensional view of an aircraft from any vantage point, an aircraft flight path, cockpit instrument panels and pilot control inputs or aircraft control surfaces deflections.

³¹ The term FOQA is also used i.e. a Flight Operations Quality Assurance program.

³² E.M. Owen (1971), *Civil Aircraft Airworthiness Data Recording Program – Achievements in Recording and Analysis of Civil Aircraft Operations 1962-1969*, RAE Farnborough.

Examples of animations are shown in Figures 24-25:

Figure 24: Animation showing a 3-d view of the aircraft and cockpit displays³³



Figure 25: Animation showing plan and elevation views of an instrument approach³⁴



³³ The investigation report, including a download of the animation, is available at: http://www.atsb.gov.au/publications/investigation_reports/2005/AAIR/air200503722.aspx

³⁴ The investigation report, including a download of the animation, is available at: http://www.atsb.gov.au/publications/investigation_reports/2005/AAIR/air200501977.aspx

6.4 Simulations

A simulation predicts how an aircraft should behave given its initial conditions, control inputs and a knowledge of the aircraft stability and control equations. The predicted behaviour can then be compared with the actual behaviour recorded by the FDR. Any differences could be due to external factors such as meteorological effects or aircraft malfunctions. In practice, only the aircraft manufacturer will have access to the mathematical models required for simulations and accident investigation authorities would work cooperatively with the manufacturer to obtain a simulation.

6.5 Comparison Techniques

A useful analysis technique is to compare incident data with routine data, for example, data from an incident approach to a certain runway can be compared with data from normal approaches to the same runway. In the 1970's and 1980's data storage was expensive³⁵ and flight data was discarded as soon as the next recorder or tape was ready for readout. Today, data collection is relatively expensive and data storage is cheap. Some airlines now routinely archive all the flight data obtained for a FDAP so that it can be analysed again at a later date if required.

An example of this technique is shown in Figure 26 where pilot pitch control inputs from 24 uneventful flights are plotted with data from an incident (tail-scraper) flight shown in red.

Figure 26: Comparison pitch control input (control column) data around rotation

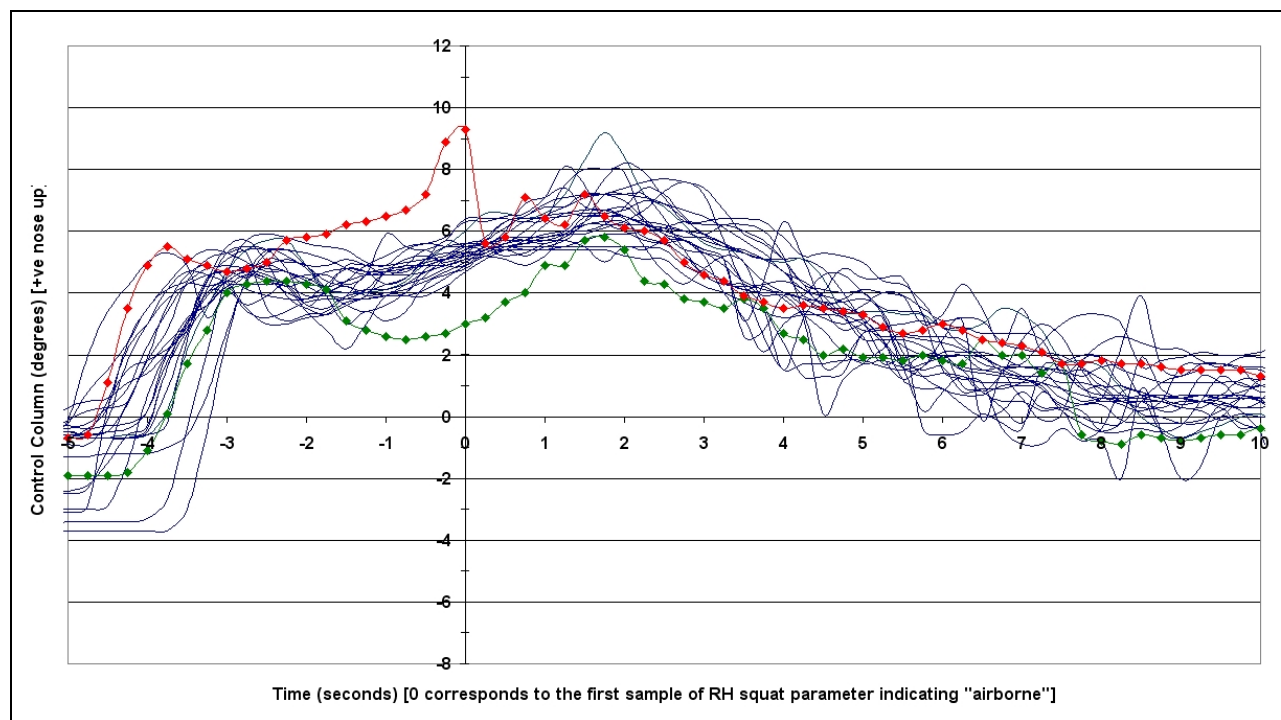

³⁵ The PDP 11/45 minicomputer shown in Figure 20 was equipped with two 40 Mbyte disk drives. In 1977, each drive cost AUD 22,450.00

6.6 Geographical Information System (GIS) Tools

The Shuttle Radar Topography Mission (SRTM) was a joint project between the National Geospatial-Intelligence Agency and the National Aeronautics and Space Administration. The objective of this project was to produce digital terrain elevation data (DTED) for 80% of the Earth's land surface (all land areas between 60° north and 56° south latitude), with data points located every 1-arc second (approximately 30 metres) on a latitude/longitude grid. The absolute vertical accuracy of the elevation data is 16 metres (at 90% confidence).³⁶ The mission was flown in February 2000 and the SRTM data is publicly available³⁷. The data publicly available for Australia is 3-arc second (approximately 90 metre) resolution.

Combining digital terrain elevation data with topographic maps or images from Google Earth can be highly effective when portraying aircraft tracks. Figure 27 gives an example using the versatile but low-cost OziExplorer³⁸ application.

Figure 27: An aircraft flight path obtained from ADS-B data

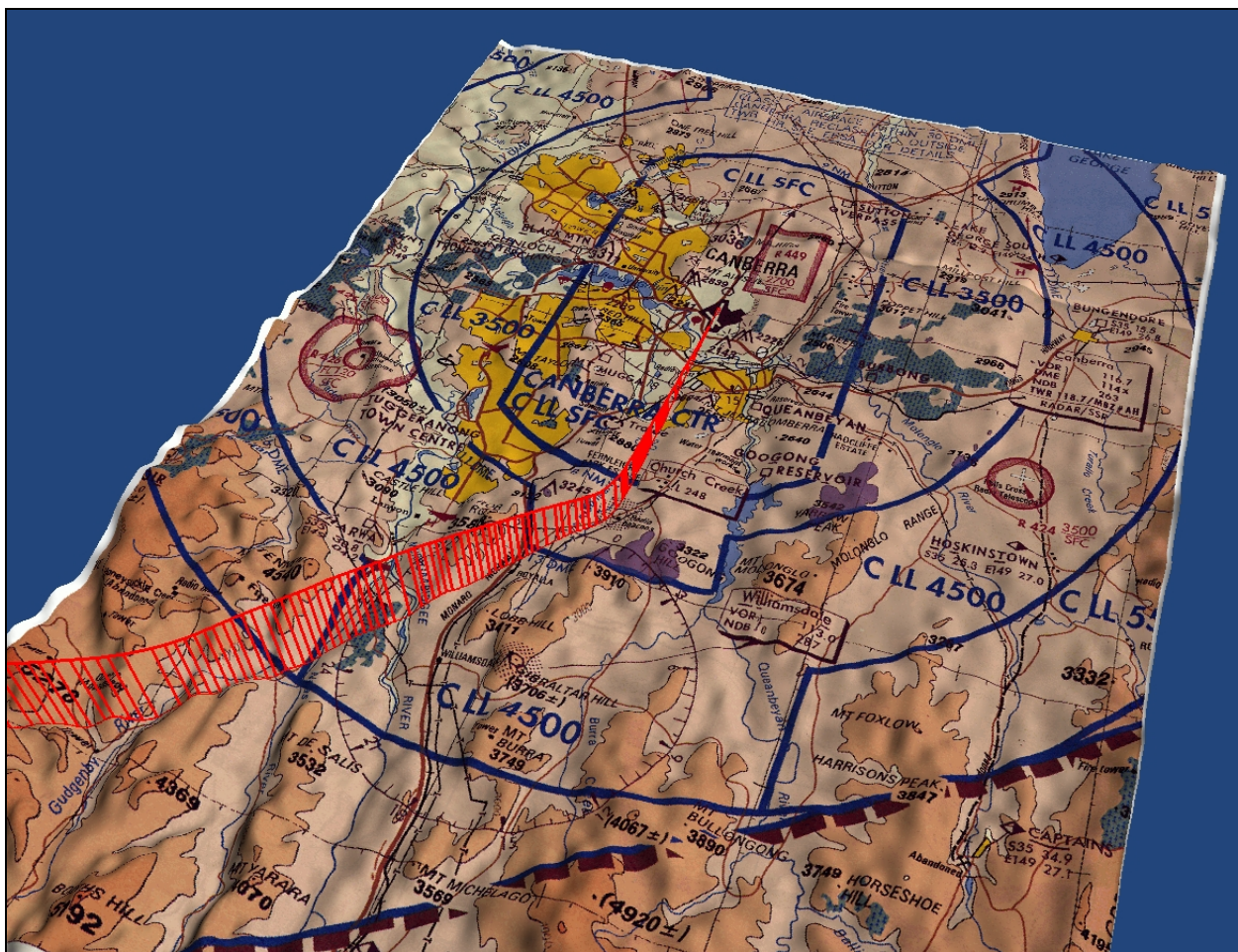

³⁶ Refer to <http://srtm.usgs.gov/index.php>

³⁷ Refer to <http://edc.usgs.gov/products/elevation.html>

³⁸ For more information: <http://www.ozexplorer.com/>

7. CONCLUSION

In the 1960's, the usefulness of flight recorders was not universally acknowledged and they were treated with scepticism in some quarters. Today they are accepted as a vital tool in the investigation of accidents and incidents. In fact, in some accidents, the recorders are the only wreckage that needs to be recovered³⁹.

The challenge for the aviation safety community is to promote the installation of suitable - lighter and less expensive - flight recorders in smaller aircraft such as the very light jets whose numbers will soon be rapidly expanding.

The challenge for flight data analysts is to ensure that flight data is validated, analysed and presented objectively and accurately.

³⁹ In 1996, a Boeing 757 crashed into the sea off the coast of the Dominican Republic, killing all 189 on board. The wreckage was at a depth of 7,200 feet that made recovery extremely expensive. The FDR recorded approximately 350 parameters and together with the CVR, provided investigators with all the data they needed to precisely define the problems and to determine the crew's actions. As a result, the only wreckage recovered was the flight recorders.